

Data sheet

HRW 2000

Usable content		l	2000
Electric motor	50 Hz	kW	3
	60 Hz	kW	3.6
Agitator speed	50 Hz	min ⁻¹	32
	60 Hz	min ⁻¹	38
Weight		kg	950

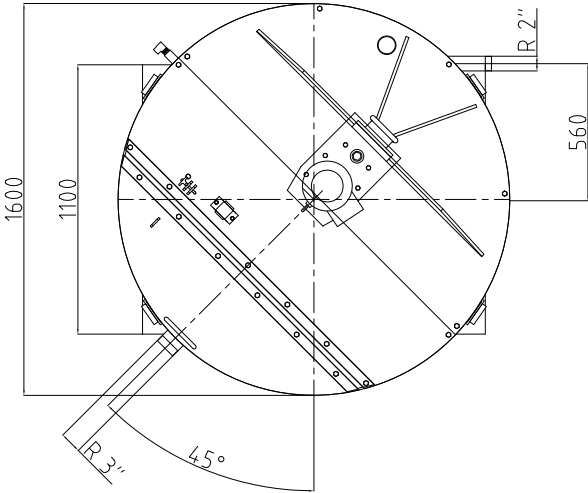
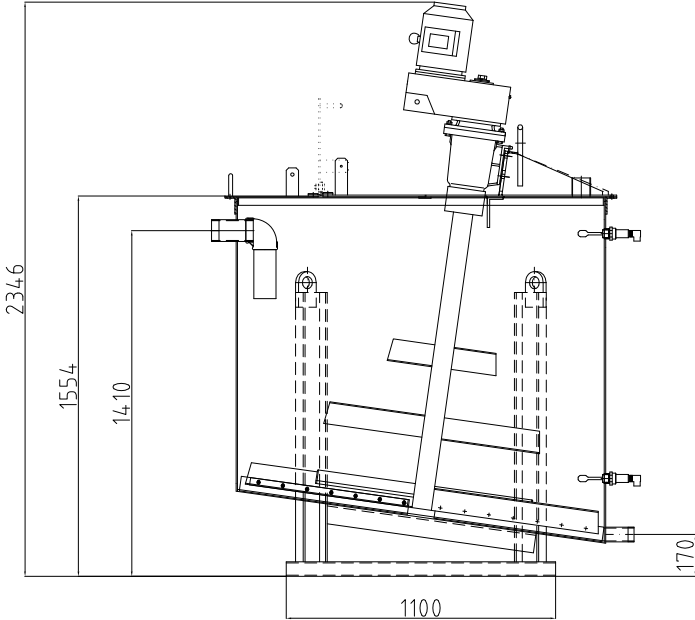

Hány AG reserves the right to make improvements and modifications to their equipment without notice.

GROUTING SYSTEMS



AGITATOR HRW 2000

The agitator HRW 2000 is used as storage tank between a batch mixer, such as the HCM, and the grout pump for continuous operation. The stirring paddle prevents the grout from settling out of suspension and removes any air bubbles from the mix. The slanting stirring paddle together with a special arrangement of the paddle blades ensure complete circulation of the tank content. A safety switch turns off the agitator whenever the tank cover is removed.

ACCESSORIES:

LEVEL PROBES 1", "FULL - EMPTY"

for the operation in automated plants

GROUTING SYSTEMS

HÄNY

